

PRINCIPALS

Daniel W. Mitchell
Nancy M.D. Faught
Keith D. McCormack
Jesse B. VanDeCreek
Roland N. Alix
Michael C. MacDonald
James F. Burton
Charles E. Hart

CONTROLLER

Donna M. Martin

SENIOR ASSOCIATES

Gary J. Tressel
Randal L. Ford
William R. Davis
Dennis J. Benoit
Robert F. DeFrain
Thomas D. LaCross
Albert P. Mickalich
Timothy H. Sullivan
Thomas G. Maxwell

ASSOCIATES

Marshall J. Grazioli
Colleen L. Hill-Stramsak
Bradley W. Shepler
Karyn M. Stickel
Jane M. Graham
Todd J. Sneathen
Aaron A. Uranga
Salvatore Conigliaro
Melissa A. Coatta
Michael P. Darga
Brian K. Davies
James E. Scholl
Matthew G. Slicker
James J. Surhigh
Trevor S. Wagenmaker

HUBBELL, ROTH & CLARK, INC.

SHIPPING: PO Box 824
Bloomfield Hills, MI 48303-0824

STREET: 555 Hulet Drive
Bloomfield Hills, MI 48302-0360

PHONE: 248-454-6300

WEBSITE: hrcenr.com

OTHER OFFICE LOCATIONS

Delhi Township
Detroit
Grand Rapids
Howell
Jackson
Kalamazoo
Lansing

**ADDENDUM NO. 1
FOR
MEMORIAL PARK
CITY OF UTICA MACOMB COUNTY, MICHIGAN**

ISSUED: February 22, 2019

HRC Job No. 20180705

This Addendum is issued prior to receipt of bids to provide for certain changes and clarifications to the Specifications, as herein specified, and is hereby made a part of the Contract Documents and shall be taken into consideration in preparing the Proposal. All other conditions remain the same. **The Bidder shall acknowledge the receipt of this Addendum by signing below, including this and the attached Proposal Sheets with their bid, and completing the Addenda section on Sheet 00300/3 of the Proposal.** Failure to utilize the Addendum No. 1 Proposal Form in the submission of bids may be justification for the bid proposal being rejected as non-responsive.

Please note that the date and time of the receipt of bids is still scheduled for Tuesday, March 12, 2019 at 2:30 p.m., at the City of Utica, City Clerk, located at 7550 Auburn Rd Utica, Michigan 48317 .

The following lists the extent of this Addendum. Descriptions of the changes or clarifications are given within each heading.

SPECIFICATIONS

Reissued:

- Advertisement Sheets 00030/1 and 00030/2 to correct project name and include bid address for City of Utica Clerk's office.
- Proposal Sheets 00300/1 through 00300/7 updated to remove bid item #17, "Excavation for Brick Pavers on Aggregate and Sand Base" due to all associated excavation is included in bid item #16, "Brick Pavers on Aggregate and Sand Base" per special provision.

PLANS

Reissued:

- Plan Sheet No. C03 to revise quantities.

Received and Acknowledged By:

Company: _____

Signature: _____

Printed Name: _____

Title: _____

Date: _____

**INVITATION FOR BIDS
MEMORIAL PARK
IMPROVEMENTS
CITY OF UTICA
MACOMB COUNTY, MICHIGAN**

Sealed proposals for the construction of the Memorial Park project will be received by the City Clerk for the City of Utica, 7550 Auburn Rd Utica, Michigan 48317, until 2:30 p.m., Local Time on **Tuesday, March 12, 2019**, at which time and place all bids will be publicly opened and read.

Bidders shall review and comply with the Instructions to Bidders, which are incorporated by reference, and carefully review all Contract Documents, as defined in the Instructions to Bidders. Bids submitted after the exact time specified for receipt will not be considered.

The Contracts will consist of the following principal items of work and appurtenances as specified herein and shown on the Contract Drawings.

<u>Description of Work</u>		
Sedum, #1	40	Ea
Day Lily, #1	40	Ea
Salvia, #1	46	Ea
Fountain Grass, 18" ht	15	Ea
Juniper	23	Ea
Crabapple, 2" cal.	2	Ea
Maple, 2" cal.	2	Ea
Ginkgo, 2" cal.	2	Ea
Wood Benches, 6 Foot	2	Ea
Brick Pavers	225	Sft

Copies of Plans and Specifications and Proposal Forms shall be available on or after **February 18, 2019** at the offices of Hubbell, Roth & Clark, Inc., Consulting Engineers, 555 Hulet Drive, Bloomfield Hills, Michigan 48302-0360. A non-refundable payment of Eighty (\$80.00) Dollars, **CHECK ONLY, payable to "Hubbell, Roth & Clark, Inc."** will be required for each set of Drawings and Specifications. Drawings and Specifications can be shipped by U.P.S. ground for a shipping and handling charge of Thirty (30.00) Dollars, **CHECK ONLY, non-refundable, to Hubbell, Roth & Clark, Inc.**

Copies of plans and specifications may also be downloaded from the Michigan Inter-Governmental Trade Network website at www.MITN.info

Proposals submitted by Bidders who have been debarred, suspended, or made ineligible by any Federal Agency will be rejected.

Each bidder agrees to waive any claim it has or may have against the Owner, the Architect/Engineer, and their respective employees, arising out of or in connection with the administration, evaluation, or recommendation of any bid.

Each bid proposal shall be submitted on the proposal forms provided and shall be accompanied by a cashier's check or bid bond, executed by the bidder and Surety Company, payable to the City of Utica in the amount of Five Percent (5%) of the accompanying bid. Proposal Guarantee shall provide assurance that the bidder will, upon acceptance of the bid, execute the necessary Contract with the City of Utica. No bid may be withdrawn after scheduled closing time for receiving bids for at least Sixty (60) days.

The successful bidder will be required to furnish satisfactory Performance, Labor and Material, and Maintenance and Guarantee Bonds.

The City of Utica reserves the right to reject all bids and to waive irregularities in bidding.

No Proposal will be received unless made on blanks furnished and delivered to the City Clerk on or before 2:30 p.m., Local time, **Tuesday, March 12, 2019.**

CITY OF UTICA

y
:
\
2
0
1
8
0
7
\
2
0
1
8
0
7
0
5
\
0
4
_
d
e
s
i
g
n
\
P
r
o
j
e
c
t
_
d
o
c
s
\
s
p
e
c
s
\
w
o
r
k
i
n
g
_
d
o
c
s
\
0
0
0
3
0
_
a
d
v
e
r
t
i
s
e
m
e
n
t
_
r
2
0
0
8
0
2
1
9
.
d
o
c

PROPOSAL
FOR
MEMORIAL PARK
CITY OF UTICA
MACOMB COUNTY, MICHIGAN

City of Utica
7550 Auburn Rd
Utica, MI 48317

Bids Due: Tuesday, March 12, 2019
On or Before 2:30 pm, Local Time

HRC Job No. 20180705

Gentlemen:

Name of Bidder: _____

Address: _____

Date: _____ Telephone: _____ Fax: _____

The above, as bidder, hereby declares this bid is made in good faith without fraud or collusion with any persons bidding, and that he has examined the plans, specifications, and all other information referenced in the Instructions to Bidders, and is familiar with the location of the work described herein and is fully informed as to the nature of the work and the conditions relating to the performance of the Contract.

The bidder acknowledges that he has not received or relied upon any representations or warranties of any nature whatsoever from the City of Utica, its agents or employees, as to any conditions to be encountered in accomplishing the work and that his bid is based solely upon the bidder's own independent judgment.

The above, as bidder, hereby certifies that he has examined the plans, specifications, and other data provided by the Owner for bidding purposes. Further, the undersigned certifies that he has reviewed the proposed construction methods and finds them acceptable for the conditions which he anticipates from the information provided for bidding.

The Bidder hereby declares that the he/she has inspected the site of work and further declares that no charges in addition to the Individual Unit Prices shall be made on account of any job circumstances or field conditions which were present and/or ascertainable prior to the bidding. In addition, The Contractor, as such and as Bidder, shall make his own determination as to existing soil conditions and he shall also complete the work under whatever conditions he may create by his own sequence of construction, construction methods, or other conditions he may create, at no additional cost to the Owner.

The above, as Bidder, declares that he has familiarized himself with the location of the proposed Memorial Park Project and appurtenant construction in the City of Utica, Macomb County, Michigan, and the conditions under which it must be constructed; also that he has carefully examined the Plans, Specifications, and Contract Documents which he understands and accepts as sufficient for the purpose of constructing said Memorial Park Project, and appurtenant work, and agrees that he will contract with the City of Utica to furnish all labor, materials, tools, equipment, facilities and supervision necessary to do all the work specified and prescribed for the City of Utica, in strict accordance with the Owner's General Conditions, and with the

full intent of the Drawings and Specifications, prepared by Hubbell, Roth & Clark, Consulting Engineers, and that he will accept in full payment therefore the sum of:

Section I

<u>Item</u>	<u>Quantity</u>	<u>Unit Price</u>	<u>Total Cost</u>
1. Grading/Earthwork for Landscaping	1 LS @	\$ _____	= \$ _____
2. Sedum 'Autumn Joy', Autumn Joy Sedum, #1	40 Ea @	\$ _____	= \$ _____
3. Hemerocallis 'Happy Returns', Happy Returns Day Lily, #1	40 Ea @	\$ _____	= \$ _____
4. Salvia N. 'May Night', May Night Salvia, #1	46 Ea @	\$ _____	= \$ _____
5. Pennisetum A. 'Little Bunny', Little Bunny Fountain Grass, 18" ht	15 Ea @	\$ _____	= \$ _____
6. J. Ch. Pfitzer Compacta, Spreading Juniper, #5 or 18" sprd	6 Ea @	\$ _____	= \$ _____
7. Malus x Zumi 'Calocarpa', Zumi Crabapple, 2" cal.	2 Ea @	\$ _____	= \$ _____
8. Malus 'Cardinal', Cardinal Crabapple, 2" cal.	3 Ea @	\$ _____	= \$ _____
9. Juniperus Virginiana 'Skyrocket', Skyrocket Juniper, 5' ht	15 Ea @	\$ _____	= \$ _____
10. Acer Saccharum, Sugar Maple, 2" cal.	2 Ea @	\$ _____	= \$ _____
11. Ginkgo Biloba, Ginkgo, 2" cal.	2 Ea @	\$ _____	= \$ _____
12. Planting Mixture	30 Cyd @	\$ _____	= \$ _____
13. Shredded Hardwood Bark Mulch	15 Cyd @	\$ _____	= \$ _____
14. Metal Landscape Edging	110 Ft @	\$ _____	= \$ _____
15. Wood Benches, 6 Foot	2 Ea @	\$ _____	= \$ _____
16. Brick Pavers on Aggregate and Sand Base	225 Sft @	\$ _____	= \$ _____

Total Amount of Bid - Section I \$ _____

Alternate 1

1. Credit for Elimination of Landscape Maintenance Warranty	1 LS @	\$ _____	= \$ _____
---	--------	----------	------------

Total Amount of Bid – Sections I minus Alternate 1 \$ _____

y : \ 2 0 1 8 0 7 \ 2 0 1 8 0 7 0 5 \ 0 4 - d e s i g n \ p r o j e c t - d o c s \ s p e c s \ w o r k i n g d o c s \ 0 0 3 0 0 - p r o p o s a l - r 2 0 1 5 0 5 7 2 . d o c 0 2 / 2 2 / 1 9 8 : 3 3 : 1 5 A M

Explanation of Alternate 1.

The Owner may elect to award the project without enforcement of the landscape warranty requirements outlined in Section 02970: Landscape Maintenance and Guarantee Standards. Contractor shall provide a lump sum price for the warranty credit which shall apply to all planting materials in Section I, including trees, shrubs and groundcover. If the owner awards the project and accepts Alternate 1, the Landscape Maintenance and Guarantee Standards will not be enforced.

Voluntary Alternates proposed by the Bidder will not be considered. The Bidder shall submit his bid based on the information shown on the Drawings and Specifications.

The Owner, at his sole discretion, reserves the right to award to the Bidder who, in the sole determination of the Owner, will best serve the interest of the Owner. The Owner reserves the right to accept any bid, to reject any or all bids, to waive any and all informalities involving price, time, or changes in the work, and to negotiate contract terms with the successful Bidder, and the right to disregard all nonconforming, nonresponsive, unbalanced or conditional bids.

Also, the Owner reserves the right to reject the bid of any Bidder if the Owner believes that it would not be in the best interest of the Project to make an award to that Bidder, whether because the bid is not responsive or the Bidder is unqualified, of doubtful financial ability, or fails to meet any other pertinent standard or criteria established by the Owner.

Each bidder agrees to waive any claim it has or may have against the Owner, the Architect/Engineer, and their respective employees, arising out of or in connection with the administration, evaluation, or recommendation of any bid.

To stay within the available project budget, The Owner, at their sole discretion, reserves the right to increase or decrease the pay item quantities or to eliminate items of work in the project contract before award or during construction. No additional compensation or adjustment to unit prices or lump sum prices will be made to the Contractor due to reduction/addition or deletion of any pay item in this contract.

Each Proposal must be accompanied by a bid deposit in the form of a certified check, cashier's check or bid bond, executed by the bidder and Surety Company, payable to the City of Utica in the amount of Five Percent (5%) of the amount of the Proposal. See Instructions to Bidders – Bid Deposit for more information.

TAXES

The Bidder affirms that all applicable Federal, State and Local taxes of whatever character and description are included in all prices stated in this Form of Proposal.

ADDENDA

The Bidder acknowledges the following Addenda, covering revisions to the drawings or specifications and the cost, if any, of such revision has been included in the quoted proposal:

Addendum No. _____ Dated _____
Addendum No. _____ Dated _____
Addendum No. _____ Dated _____

FEES

The Bidder shall refer to the General Conditions for allowable Fees for additional work performed, upon Owner's written authorization, by Bidder's own forces and/or for additional work, upon Owner's written authorization, by Bidder's subcontractors.

TIME OF COMPLETION

If awarded the Contract for the Memorial Park Project, we agree to have all work completed by **June 1, 2019**, including final restoration and cleanup.

The Bidder hereby agrees to furnish the required Bonds, Insurance Certificates, and Policies within ten (10) days after acceptance of this Proposal.

The execution of all work and specific constraints as described in the contract drawings and specifications, with particular reference to Section 02030 Sequence of Construction and Special Project Requirements, must be strictly adhered to.

LIQUIDATED DAMAGES

Time is of the essence for completion of this project in order to have the Project ready for the City of Utica. The Bidder guarantees that he/she can and will complete the work within the time limit stated hereinbefore or within the time as extended as provided elsewhere in the Specifications. Inasmuch as the damage and loss to the Owner which will result from the failure of the Bidder to complete the work within the stipulated time, will be most difficult or impossible to accurately determine, it is mutually agreed that the damages to the Owner for such delay and failure on the part of the Bidder shall be liquidated in the amount of Five Hundred Dollars (\$500.00), for each and every calendar day by which the Bidder shall fail to complete the work or any part thereof within the provisions hereof, and such liquidated damages shall not be considered as a penalty.

The Owner will deduct and retain out of any money due or to become due hereunder the amount of the liquidated damages, and in case those amounts are less than the amount of actual liquidated damages, the Bidder shall pay the difference upon demand of the Owner.

We understand that liquidated damages may be assessed should we fail to meet the stipulated completion date. Specifically, liquidated damages will be assessed daily beginning **June 2, 2019** until such a time that Final Completion requirements are met.

BIDS TO REMAIN FIRM

The price stated in this Proposal shall be guaranteed for a period of not less than 45 days from the bid due date and if authorized to proceed within that period, the bidder agrees to complete the work covered by the Proposal at said price.

If this Proposal is accepted by the Owner and the undersigned shall fail to contract as aforesaid and to furnish the required surety bonds within fifteen (15) days after being notified of the acceptance of his/her/her bid, then the undersigned shall be considered to have abandoned the contract, and the Certified Check, Cashier's Check or Bid Bond accompanying this Proposal shall be forfeited to the City of Utica.

y :
\
2
0
1
8
0
7
\
2
0
1
8
0
7
0
5
\
0
4
-
d
e
s
i
g
n
\
p
r
o
j
e
c
t
-
d
o
c
s
\
s
p
e
c
s
\
w
o
r
k
i
n
g
d
o
c
s
\
0
0
3
0
0
-
p
r
o
p
o
s
a
l
-
r
2
0
1
5
0
5
7
2
.
d
o
c
0
2
/
2
2
/
1
9
8
:
3
3
:
1
5
A
M

CITY OF UTICA
MEMORIAL PARK
ADDENDUM NO. 1

PROPOSAL
00300 / 5

If the undersigned enters into the contract in accordance with his/her proposal, or if his/her proposal is not accepted, then the accompanying bid guarantee shall be returned to the undersigned.

Company Name: _____

Signature: _____ Title: _____

Address: _____

County: _____ State: _____

Telephone No.: _____ Fax No.: _____

Email Address: _____

LEGAL STATUS OF BIDDER

This Bid is submittal in the name of:

(Print) _____

The undersigned hereby designates below his/her business address to which all notices, directions or other communications may be served or mailed:

Street _____

City _____

State _____ Zip Code _____

The undersigned hereby declares that he/she has legal status checked below:

- INDIVIDUAL
- INDIVIDUAL DOING BUSINESS UNDER AN ASSUMED NAME
- CO-PARTNERSHIP
The Assumed Name of the Co-Partnership is registered in the County of _____, Michigan
- CORPORATION INCORPORATED UNDER THE LAWS OF THE STATE OF _____
_____. The Corporation is
- LICENSED TO DO BUSINESS IN MICHIGAN
- NOT NOW LICENSED TO DO BUSINESS IN MICHIGAN

The name, titles, and home addresses of all persons who are officers or partners in the organization are as follows:

A corporation duly organized and doing business under the laws of the State of _____

NAME AND TITLE	HOME ADDRESS
_____	_____
_____	_____
_____	_____

Signed and Sealed this _____ day of _____, 20__.

By (Signature)

Printed Name of Signer

Title

BID BOND

KNOW ALL MEN BY THESE PRESENTS, that we, the undersigned, _____

As Principal, hereinafter called the Principal, and _____

A corporation duly organized under the laws of the State of _____

As surety, hereinafter called the SURETY, are held and firmly bound unto:

The Owner: _____

in the sum of _____ Dollar (\$ _____),

For the payment of which sum well and truly to be made, the said Principal and the said Surety, bind ourselves, our heirs, executors, administrators, successors and assigns, jointly and severally, firmly by these presents.

WHEREAS, the Principal has submitted a bid for _____

NOW, THEREFORE, if the OWNER shall accept the bid of the Principal and the Principal shall enter into a contract with the OWNER in accordance with the terms of such bid, and give such bond or bonds as may be specified in the CONTRACT DOCUMENTS with good and sufficient surety for the faithful performance of such contract and for the prompt payment of labor and material furnished in the prosecution thereof, or in the event of the failure of the Principal to enter such contract and give such bond or bonds, if the Principal shall pay to the OWNER the difference not to exceed the penalty hereof between the amount specified in said bid and such larger amount for which the OWNER may in good faith contract with another party to perform the work covered by said bid, then his/her obligation shall be null and void, otherwise to remain in full force and effect.

Signed and sealed this _____ day of _____, 20____

(Witness) (Principal) (Seal)

(Title)

(Witness) (Surety)

(Title)

END OF SECTION

y : \ 2 0 1 8 0 7 \ 2 0 1 8 0 7 0 5 \ 0 4 - d e s i g n \ p r o j e c t - d o c s \ s p e c s \ w o r k i n g d o c s \ 0 0 3 0 0 0 - p r o p o s a l - r 2 0 1 5 0 5 7 2 . d o c 0 2 / 2 2 / 1 9 8 : 3 3 : 1 5 A M

AUBURN ROAD



QUANTITIES THIS SHEET			
NO.	DESCRIPTION	UNIT	QTY.
1	Grading/Earthwork for Landscaping	LS	1
2	Sedum 'Autumn Joy', Autumn Joy Sedum, #1	Ea	40
3	Hemerocallis 'Happy Returns', Happy Returns Day Lily, #1	Ea	40
4	Salvia N. 'May Night', May Night Salvia, #1	Ea	46
5	Pennisetum A. 'Little Bunny', Little Bunny Fountain Grass, 18" ht	Ea	15
6	J. Ch. Pfizer Compacta, Spreading Juniper, #5 or 18" Sprd	Ea	6
7	Malus x Zumi 'Calocarpa', Zumi Crabapple, 2" cal.	Ea	2
8	Malus 'Cardinal', Cardinal Crabapple, 2" cal.	Ea	3
9	Juniperus Virginiana 'Skyrocket', Skyrocket Juniper, 5' ht	Ea	15
10	Acer Saccharum, Sugar Maple, 2" cal.	Ea	2
11	Ginkgo Biloba, Ginkgo, 2" cal.	Ea	2
12	Planting Mixture	Cyd	30
13	Shredded Hardwood Bark Mulch	Cyd	15
14	Metal Landscape Edging	Ft	110
15	Wood Benches, 6 Foot	Ea	2
16	Brick Pavers on Aggregate and Sand Base	Sft	225

GENERAL NOTES:
 SHREDDED HARDWOOD BARK MULCH SHALL BE SIMILAR IN COLOR TO EXISTING MULCH.
 BRICK PAVERS SHALL BE SIMILAR IN SIZE AND COLOR TO EXISTING BRICK PAVERS.

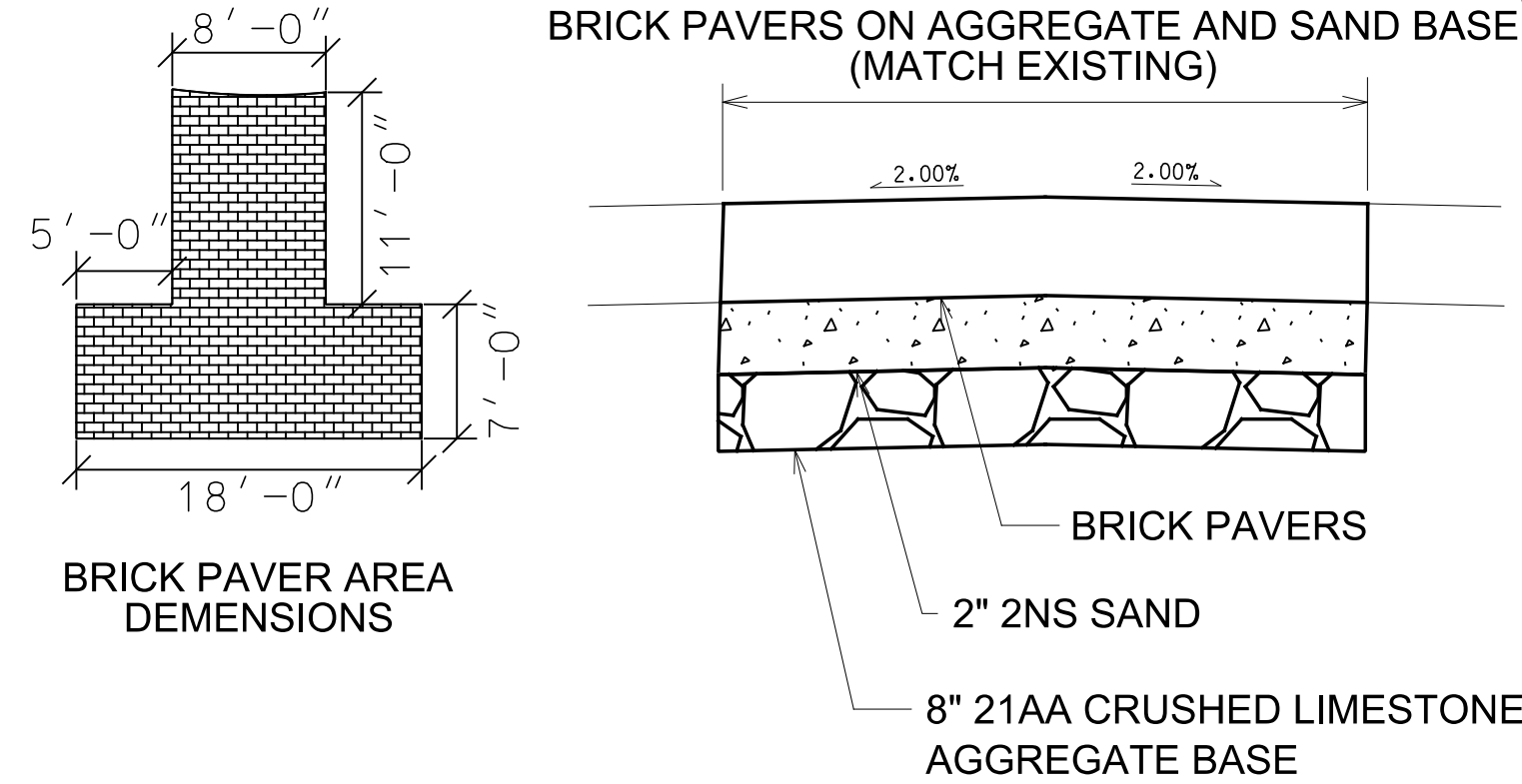

PLANT SPECIES PLANT LIST				
KEY	BOTANICAL NAME	COMMON NAME	SIZE	NOTES
SAJ	Sedum 'Autumn Joy'	Autumn Joy Sedum	#1	Cont.
HHR	Hemerocallis 'Happy Returns'	Happy Returns Day Lily	#1	Cont.
SMN	Salvia N. 'May Night'	May Night Salvia	#1	Cont.
FGB	Pennisetum A. 'Little Bunny'	Little Bunny Fountain Grass	18" ht	Cont.
JPN	J. Ch. Pfizer Compacta	Spreading Juniper	#5 or 18" sprd.	Cont.
ZC	Malus x Zumi 'Calocarpa'	Zumi Crabapple	2" cal.	B & B
CC	Malus 'Cardinal'	Cardinal Crabapple	2" cal.	B & B
SR	Juniperus Virginiana 'Skyrocket'	Skyrocket Juniper	5' ht	B & B
SM	Acer Saccharum	Sugar Maple	2" cal.	B & B
GK	Ginkgo Biloba	Ginkgo	2" cal.	B & B

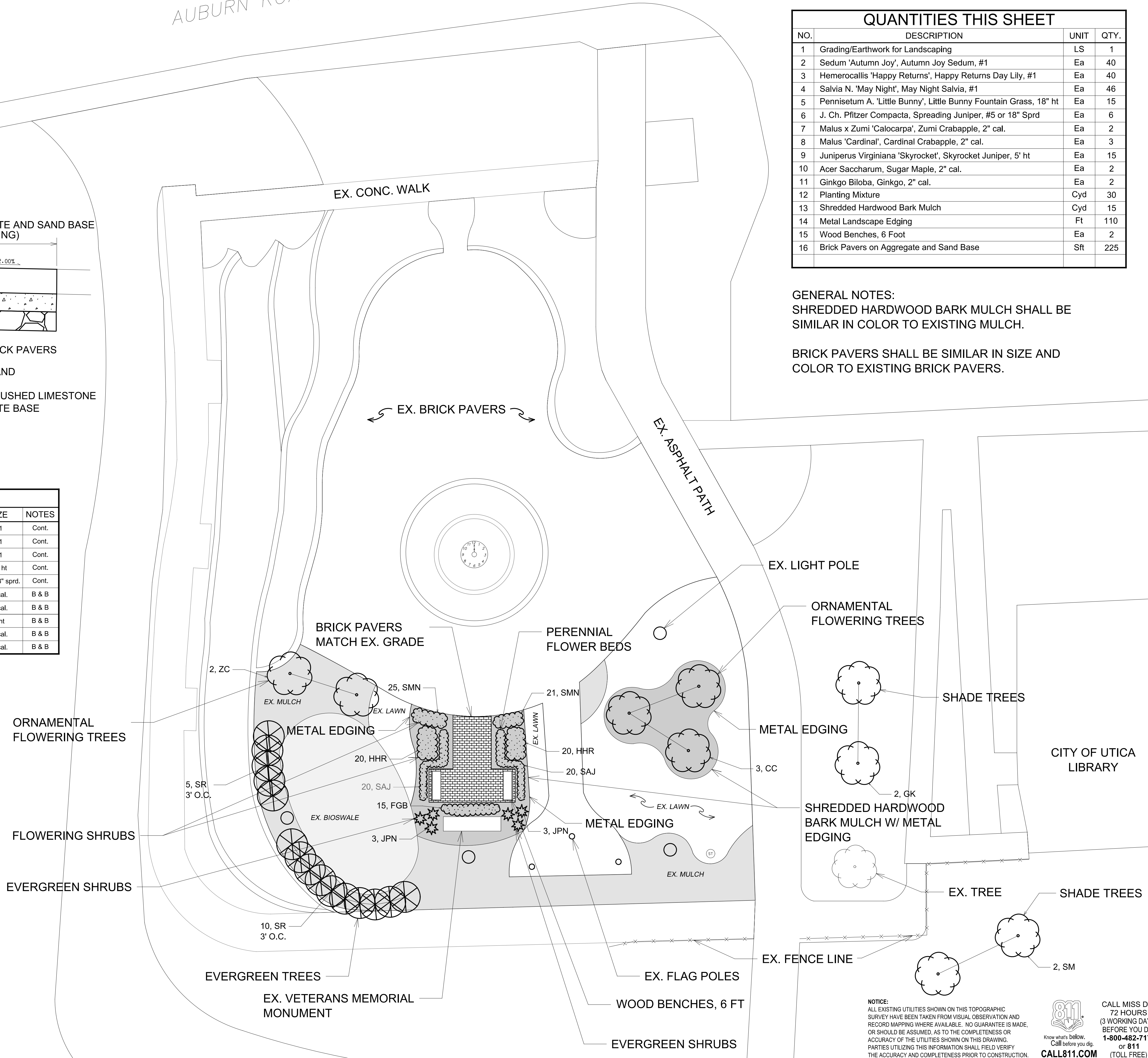

HRC
HUBBELL, ROTH & CLARK, INC
 CONSULTING ENGINEERS SINCE 1915
 555 HULET DRIVE P.O. BOX 824
 BLOOMFIELD HILLS, MICH. 48303 - 0824
 PHONE: (248) 454-6300
 FAX (1st. Floor): (248) 454-6312
 FAX (2nd. Floor): (248) 454-6359
 WEB SITE: <http://www.hrcengr.com>

DATE	ISSUED FOR / ADDITIONS / REVISIONS
2-22-19	ADDENDUM 1
2-16-19	ISSUED FOR BIDS
DATE	ISSUED FOR / ADDITIONS / REVISIONS
DESIGNED	SC
DRAWN	ALE
CHECKED	SC
APPROVED	

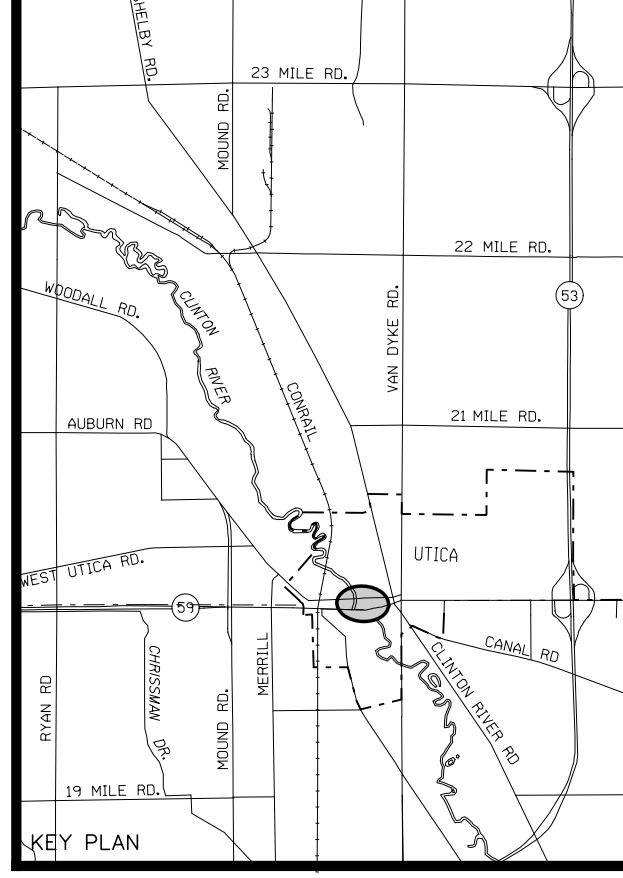

PROJECT TITLE	
CITY OF UTICA	
MEMORIAL PARK	
SHEET TITLE	
CONSTRUCTION PLAN	
HRC JOB NO.	SCALE
20180705	1" = 10'
DATE	SHEET NO.
September 2018	C 03

NOTICE:
 ALL EXISTING UTILITIES SHOWN ON THIS TOPOGRAPHIC SURVEY HAVE BEEN TAKEN FROM VISUAL OBSERVATION AND RECORD MAPPING WHERE AVAILABLE. NO GUARANTEE IS MADE, OR SHOULD BE ASSUMED, AS TO THE COMPLETENESS OR ACCURACY OF THE UTILITIES SHOWN ON THIS DRAWING. PARTIES UTILIZING THIS INFORMATION SHALL VERIFY THE ACCURACY AND COMPLETENESS PRIOR TO CONSTRUCTION.

CALL MISS DIG 72 HOURS (3 WORKING DAYS) BEFORE YOU DIG
 1-800-482-7171 or 811 (TOLL FREE)

811
 Know what's below. Call before you dig. CALL811.COM

HRC\201807\20180705\C\1\Sheets\c01\p001.dgn
 sc01g1010